

REV. 版本	ECN NO. 变更单号	DESCRIPTION 变更说明	DATE 日期
01		新案开发	2019.02.27

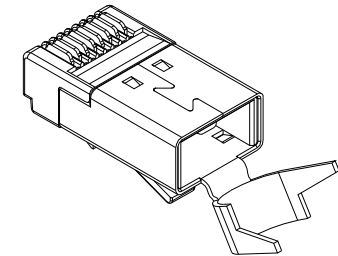
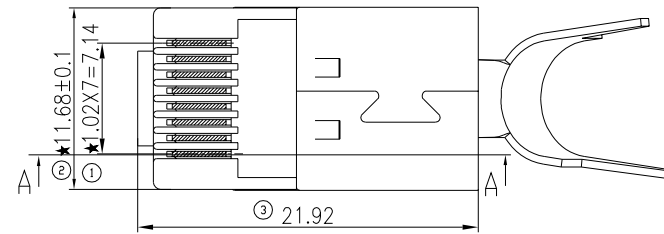
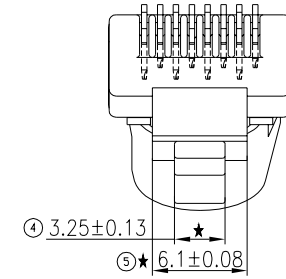
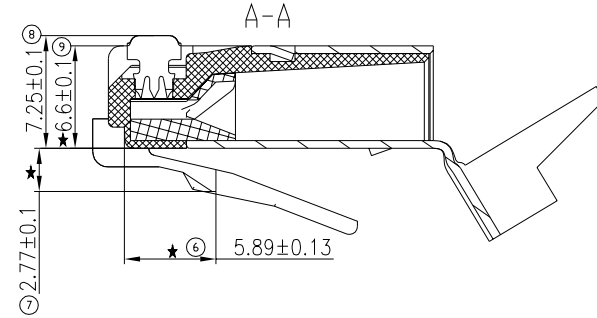
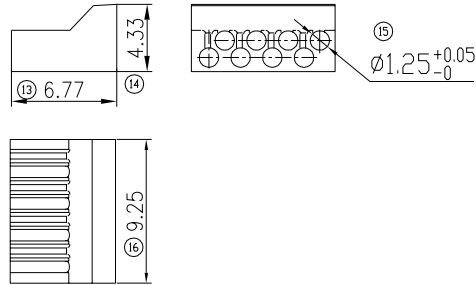

SPECIFICATION NOTES:

ELECTRICAL:

- VOLTAGE RATING: 150 VAC RMS
- CURRENT RATING: 1.5 AMP
- CONTACT RESISTANCE: 20m MAX.
- INSULATION RESISTANCE: 1000M MIN. AT 500V DC.
- 1000V D.C. or A.C. PEAK; ONE CONTACT TO ALL OTHER CONTACTS CONNECTED TOGETHER. 1500V D.C. OR A.C. PEAK; ALL CONTACTS CONNECTED TOGETHER TO SHIELD, (HOUSING/MOUNTING PLATE) IF PRESENT.
@ 0.5mA 50 Hz OR 60 Hz A MINUTE

SALT SPRAY	
G/F	NA
3u" 6u"	24H
15u" 30u" 50u"	48H

MECHANICAL:

- RETENTION STRENGTH: 50N MIN. FOR 60S±5S
- OPERATING LIFE: 750 CYCLES MIN.
- INSERTION FORCE: 30N MAX.

ENVIRONMENTAL:

- OPERATION: -25 ~ +55 GB 10753-89
- STORAGE: -10 ~ +40 RELATIVE HUMIDITY < 80%, GB 10753-89
- STORAGE TIME: 12 MONTHS

CHARACTERISTICS:

PLUG WILL ACCEPT 21 OR 23 AWG SOLID FTP WIRE HAVING A MAXIMUM INSULATION DIAMETER OF 1.14-1.24 MM AND A MAXIMUM DIAMETER CABLE JACKET OF 7.70 MM

RoHS Compliant u"=μinch



TOLERANCES 公差				Material: 材质	Designed: 设计	NAME: 名称	REV. 版本
00~15	±0.15	PC 普通透明环保		潘晓瑶			
15~30	±0.20	Finish: 电 镀	Au: 15u"	Checked: 审核		DWG NO: 图号	
30~	±0.25	ANGLES: ±1°		Approved: 核准		PART NO: 料号	
SHEET 1 OF 1 第1页 共1页						04-004-001-6A	01

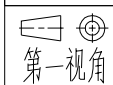

A4
SIZE

SCALE 比例
1:1

UNIT 单位
mm

CUSTOMER: 客户
MODEL NO: 料号